

# Scheda articolo IT006

## FLANGIA

**Realizzata in:** ACC.ZINC.E.B.  
**Codifica finitura:** A04  
**Trattamento:** zincatura  
**Spessore:** da 7-8um  
**Rif.normativa:** UNI 2081

**Componente**  
 1- Flangia  
 2- Dado 1/2" UNI 5588

**Classe materiale**  
 FeP11  
 AVP

**Dimensioni**  
 3x1250x2000  
 Tornito barra CH27

**Rif. normativa**  
 UNI 10111  
 -

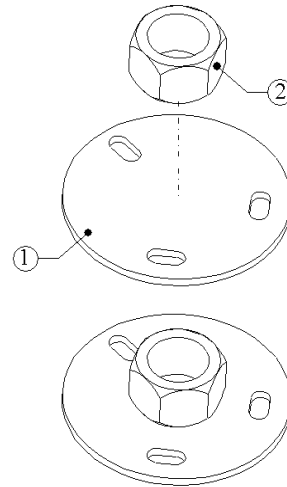
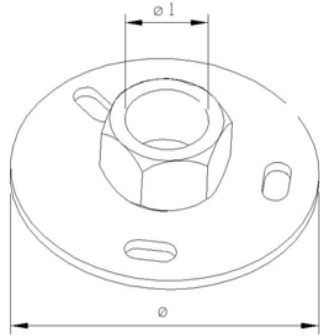

Codice articolo	ø (mm)	ø1 "	Scatola (mod)	Imballaggio (pz)	Confezione (pz)
IT006A0401	70	1/2	5	100	10
IT006A0402	70	M10	5	100	10